

Attitude and Heading Reference System

INNALABS[®] AHRS M3

Datasheet

© 2008, Innalabs[®]

This document contains information proprietary to Innalabs

The **Innalabs® Attitude and Heading Reference System (AHRS)** is a high-performance strapdown system that determines the full angular orientation of any vehicle or other carrier in the 3D space. The Innalabs® AHRS estimates vehicle orientation angles with a high accuracy for both motionless and moving vehicles. Also short magnetic disturbances do not influence the Innalabs® AHRS heading accuracy. Specially designed software allows simple field calibration of the Innalabs® AHRS to eliminate magnetic deviations caused by soft- and hard-iron materials of a vehicle.

FEATURES

- Real-time high-accuracy roll, pitch and heading angles in dynamic environment
- 3-axis gyro, accelerometer and magnetometer outputs
- Fully compensated over wide temperature range
- Small dimensions
- Low power consumption
- Shock & vibration resistant
- Environmentally sealed case
- RS-232 serial outputs (USB outputs are optional)



APPLICATIONS

- Land vehicle control
- Remotely operated vehicles
- Avionics systems
- Marine vehicles
- Platform stabilization
- Robotics

The Innalabs® AHRS has a sensor unit that consists of three gyros, three accelerometers and a high-accuracy triaxial fluxgate magnetometer. The AHRS uses gyros to measure absolute angular rates of the AHRS carrier. The vehicle orientation angles (heading, pitch and roll) are calculated through special integration of gyros outputs. The accelerometers are used to determine initial attitude of the AHRS and to correct gyros drifts in the tilt angles (pitch, roll) in the operation mode. The magnetometers are used to determine initial alignment of the AHRS in azimuth and to correct gyro drifts in the heading angle.

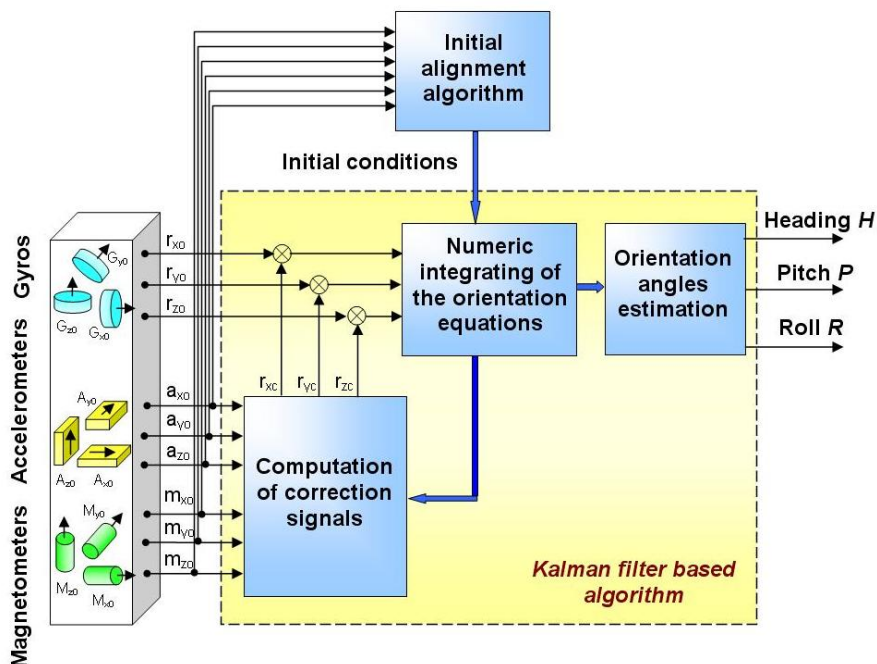

Innalabs® AHRS Block Diagram

SPECIFICATIONS

Parameter	Unit	AHRS M3
Update Rate	Hz	1....100 (user settable)
Start-up Time	sec	< 1
Full Accuracy Data (Warm-up Time) ⁽¹⁾	sec	60
Heading		
Range	deg	0 to 360
Static Accuracy at Normal Conditions (Tc=25°C)	deg	< 0.5 ⁽²⁾
Static Accuracy in Temperature Range (Tc=-40°C to +70°C)	deg	< 0.8 ⁽²⁾
Dynamic Accuracy	deg RMS	1.0 ⁽³⁾
Noise (at 100Hz output)	deg RMS	0.03
Resolution	deg	0.01
Attitude		
Range: Pitch, Roll	deg	±90, ±180
Static Accuracy at Normal Conditions (Tc=25°C)	deg	< 0.1
Static Accuracy in Temperature Range (Tc=-40°C to +70°C)	deg	< 0.3
Dynamic Accuracy	deg RMS	0.4 ⁽³⁾
Noise (at 100Hz output)	deg RMS	0.02
Resolution	deg	0.01
Angular Rate		
Input Range: Yaw, Pitch, Roll	deg/sec	±300
Bias stability at constant temperature	deg/sec RMS	0.02
Bias stability in Temperature Range (Tc=-40°C to +70°C)	deg/sec RMS	0.1
Scale Factor Accuracy	% FS	0.1
Non-Linearity	% FS	0.1
Random Walk	deg/√hr	6
Resolution	deg/sec	0.01
Bandwidth	Hz	40
Linear acceleration		
Input Range: X/Y/Z	g	±2
Bias at Normal Conditions (Tc=25°C)	mg RMS	0.3
Bias in Temperature Range (Tc=-40°C to +70°C)	mg RMS	1.0
Scale Factor Accuracy	% FS	< 0.1
Non-Linearity	% FS	0.2
Random Walk	m/s/√hr	0.06
Resolution	mg	0.1
Bandwidth	Hz	40
Environment		
Operating Temperature	deg C	-40 to +70
Non-Operating Temperature	deg C	-55 to +85
Electrical		
Input Voltage	VDC	+5.5 to +6.5
Input Current	mA	< 110
Power Consumption	W	0.66
Digital Output Format		RS-232
Physical		
Size	mm	109 x 31 x 29 (case), 127 x 31 x 29 (with mounting lugs and connector)
Weight	kg	0.19 / 0.16 ⁽⁴⁾
Connector		5-Pin Binder 719 (Male)

Notes:

- (1) including time of initial alignment, it may be decreased on request;
- (2) in homogeneous magnetic environment, for magnetic latitude up to ± 65 deg;
- (3) root mean square error (1 sigma), may depend on type of motion;
- (4) depends on material of the AHRS case.

The high accuracy of the Innalabs® AHRS is provided by (a) accurate calibration of all AHRS sensors over the whole temperature range after manufacturing of each AHRS; (b) automatic field calibration to compensate hard and soft iron influence on the AHRS magnetometers; and (c) the use of sophisticated algorithms to determine stabilized roll, pitch and heading angles both in static and dynamic conditions.

The Innalabs® AHRS accelerometers are calibrated on a positioning table (PT) that provides the AHRS accurate positioning with respect to the horizon plane. The PT also provides accurate positioning of the AHRS in tests to evaluate its attitude static accuracy. The test plate of the PT with the AHRS mounted on it is located in a temperature chamber. This provides temperature calibration of the AHRS accelerometers and testing of the AHRS attitude accuracy over the whole temperature range. The Innalabs® AHRS gyros are calibrated over the temperature range when AHRS is mounted on a high-accuracy rotating table in a temperature chamber. The AHRS magnetometers are calibrated in a special nonmagnetic test area (the deviation of the magnetic field intensity of the test area from the Earth magnetic field is less than 0.01%) using 3-axes Helmholtz coils with a nonmagnetic temperature chamber inside. This equipment provides both accurate magnetometer calibration and test of the AHRS heading accuracy over the temperature range. Also a special nonmagnetic theodolite is used to test the AHRS heading accuracy in the real Earth magnetic field environment.

The Innalabs® AHRS software takes into account the influence of the carrier object soft and hard iron on the heading angle accuracy. For this purpose, a field calibration procedure of the AHRS magnetometers is provided. This calibration does not require any additional equipment, but it requires turns of the carrier object where the AHRS is mounted. Both 2D and 3D calibrations are supported (when carrier object should rotated in horizon plane only or along all 3 axes).

