

The **Innalabs® CVG-43 Gyro** is designed for measuring the angular rate and orientation. Innalabs® has developed hemispherical resonator gyroscopes with metal alloy resonators. They are ideal for applications that demand high operation accuracy, low cost, and good shock and vibration resistance. The gyroscopes have a unique design and structure that significantly reduces the requirements for production facilities (patents pending).

#### FEATURES

- High-performance bias stability
- Low noise
- Light weight
- Long life and high reliability
- Excellent vibration performance
- Free for export
- Low price

#### APPLICATIONS

- Land vehicle control
- Remotely operated vehicles
- Avionics systems
- Borehole surveying
- Missiles and rockets
- Naval equipment
- Platform stabilization
- Robots



The Innalabs® Coriolis Vibratory Gyroscope (CVG) is the world's first low-cost, high performance gyroscope utilizing the superior technology provided by Coriolis Vibratory techniques. Our patented design delivers high performance and low cost in a small form-factor. With no moving parts, the CVG is designed for outstanding performance under harsh environmental conditions, and is ideally suited for a wide range of commercial, aerospace and military applications.

The Innalabs® CVG-43 output interface is RS-232. The CVG gyro output signal is digital one and comes to user in the digital form as a number of counts averaged over sample time. This number of counts should be divided by scale factor to obtain average value of angle rate in deg/s. Gyro output signals are fully processed by ADSP 21992 (wave control, modulation, demodulation and so on).

The CVG-43 sensing element is a metallic alloy cylindrical resonator. There are eight piezoelectrodes glued onto the cylindrical resonator. The electrodes are used by diametrically opposite pairs: two electrodes are located on the antinodal points of the drive mode to excite standing wave; two – to read out the response to excitation; two electrodes – on the nodal points of the drive wave – are used to read-out signals proportional to the angle rate; and two electrodes to apply the compensation force.

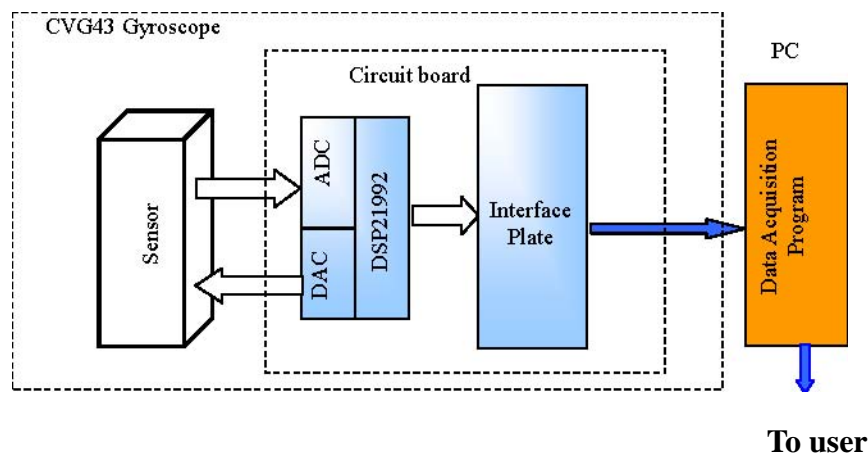

SPECIFICATIONS

Parameter	Unit	Value
Input angular rate	deg/s	±200
Bandwidth	Hz	100
<b>Normal Environmental Condition</b>		
Bias stability	deg/hr	0.03
Random Walk	deg/√hr	0.003 ~ 0.005
Scale factor linearity	ppm	300 ~ 500
<b>Temperature Range [-40 to +50] °C</b>		
Bias stability (Allan Variance)	deg/hr	0.1
Random Walk	deg/√hr	0.01
<b>Environmental</b>		
Operating temperature range	deg C	-40 ~ +50
Vibration – operational (10 - 1000Hz)	g RMS	1
Shock – operational (along the sensing axis)	g	7000
<b>Physical</b>		
Supply voltage	DCV	±7 ~ ±36
Power	watts	2.5
Interface		RS-485
Dimension 1 axis	mm	79 W x 65 H x 64 L
Weight	g	300

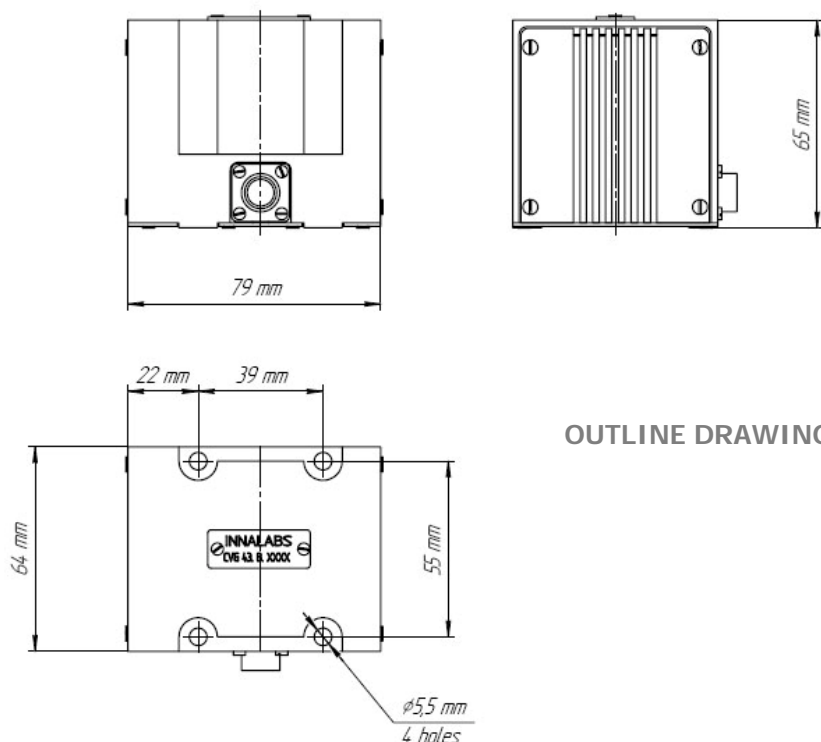

OUTLINE DRAWING

**CONNECTOR PINOUT**

Voltage supply to Innalabs® CVG-43 and information output are provided through single output connector MR-1-19 located on the gyro. The figure depicts the connector pin assignments.

MR1-19-5B

Pin	Circuit
1	DGND
2	TxD
3	RxD
4	GND
5	GND
6	+ 5 V
7	+ 5 V
8	NC
9	NC
10	NC
11	NC
12	NC
13	NC
14	NC
15	NC
16	NC
17	NC
18	NC
19	NC

