

MEMS Capacitive Accelerometers

Data sheet

MS8000.D

30S.MS8X.1.08.07

Features

Excellent bias stability
± 2g, ±10g, ± 30g, ± 100g Full scale range
Harsh environment (shock, vibration, temperature)
Low cost for advanced specifications
Low power analog voltage output
Brown out protected
LCC 48
Integrated temperature sensor

Applications

Inertial sensing
 IMU / AHRS for MilAerospace
 Avionic
 UAV
 Land navigation
 Directional drilling (oil & gas)

Tilt sensing
 Train applications
 Transportation
 Stabilization

Description

Colibrys MS8000 accelerometers are ideal products for a wide range of applications in the domains of **inertial** and **tilt / inclination** sensing. The robust and low power design combined with an excellent bias stability guarantee the superior reliability of the MS8000 MEMS accelerometer.

The Colibrys MS8000 accelerometer is a MEMS capacitive sensor, based upon a bulk micro-machined silicon element, a low power ASIC for signal conditioning, a micro-controller for storage

of compensation values and a temperature sensor. The product is low power, calibrated, robust and stable and the electronic configuration provides a solid power on reset and a full protection against brown-out.

Long-term stability of bias and scale factor are typically less than 0.1% of full-scale range. For the ± 2g version (MS8002.D), typical bias temperature coefficient is 100 $\mu\text{g}/^\circ\text{C}$ and scale factor temperature coefficients 100 ppm/ $^\circ\text{C}$.

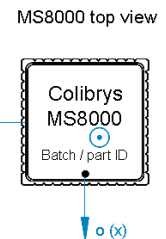
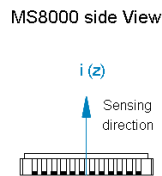
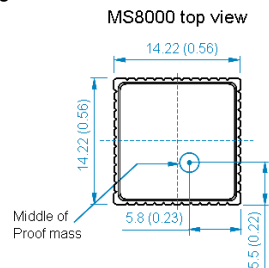
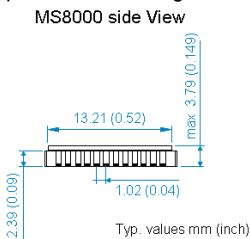

Specifications

All values are specified at +20°C (+86°F) and 5.0 VDC supply voltage, unless otherwise stated

	Units	MS8002.D	MS8010.D	MS8030.D	MS8100.D
Full scale range	g	± 2g	± 10g	± 30g	± 100g
Packaging		LCC 48	LCC 48	LCC 48	LCC 48
Bias calibration	mg	< 10	< 50	< 150	< 500
Bias stability over 48h [1]	mg typ.	< 0.05	< 0.25	< 0.75	< 2.5
One year bias stability [2]	mg typ. (max.)	1.5 (< 5)	7.5 (< 25)	22 (< 75)	75 (< 250)
Switch on/off repeatability	mg max.	< 0.15	< 0.75	< 1.5	< 7.5
Bias temp. coefficient [3]	mg/ $^\circ\text{C}$ typ.	0.1	0.5	1.5	5
	mg/ $^\circ\text{C}$ max.	± 0.4	± 2	± 6	± 20
Scale factor sensitivity (K1)	mV/g	1000 ± 8	200 ± 2	66.6 ± 1	20 ± 1
One year scale factor stability [2]	ppm typ. (max.)	300 (< 1000)	300 (< 1000)	300 (< 1000)	300 (< 1000)
Scale factor temp. coefficient [3]	ppm / $^\circ\text{C}$ typ.	100	100	100	100
	min. / max.	-50 / 250	-50 / 250	-50 / 250	-50 / 250
Input axis misalignment (Kp, Ko)	mrad max.	< 10	< 10	< 10	< 10
	% max	1	1	1	1
Resolution / Threshold (@ 1Hz)	mg max.	< 0.1	< 0.6	< 1.7	< 5.5
Non linearity	% of FS max.	< 0.8	< 0.9	< 0.9	< 1
	g max.	< 0.02	< 0.09	< 0.27	< 1
Bandwidth [4]	Hz	0 to ≥ 200	0 to ≥ 200	0 to ≥ 100	0 to ≥ 200
Noise spectral density in band [0 ; 9kHz)	$\mu\text{V}/\sqrt{\text{Hz}}$ typ.	11	11	11	11
	max.	< 18	< 18	< 18	< 18
Resonant frequency	kHz	1.4	3.7	6.3	11.5

[1]: Measurements @ 20°C during 48h as IEEE 1293-1998 12.3.8; 1h stabilization before measurements

[2]: One year stability defined according to IEEE 528-2001: turn on / turn on, storage at -55°C and 85°C, -40°C to 125°C T cycling, -55°C to 85°C unpowered harass, vibration and shock

[3]: Temperature coefficients are specified for a range of -40°C to 20°C, where temperature behavior is typically linear.

[4]: The bandwidth is defined as the frequency band for which the sensitivity has decreased by less than 3dB.

Environmental	MS8002.D	MS8010.D	MS8030.D	MS8100.D
Operating temperature range	-55°C to +125°C (-67°F to 255°F)			
Reliability	Results based on MIL-HDBK-217, notice 2, are available on request.			
Shock resistance	10'000 g (0.2ms half-sine period, shocks in each direction o, p, i)			
Recovery time	< 1ms (1000g, half-sine period 1ms, shocks in direction i)			
Vibration	20 g rms, 20-2000 Hz (random noise, 30 minutes in each direction o, p, i)			
LCC packaging	The product has been qualified according to MIL-STD-883-E. Hermetic sealing is qualified at 5·10 ⁻⁸ atm·cm ³ /s			
ESD sensitivity	Class 2 (requirements MIL-STD-883-E, 1 Method 3015.7), HBM 2kV			
Note:	- LCC must be tightly fixed to the PCB, using the bottom of the housing as reference plan for axis alignment. - See the Application Note "LCC48, mounting and soldering conditions", available on demand or on our web site for more details			

Electrical

Input voltage (VDD – VSS)	2.5 to 5.5 VDC. The standard voltage for calibration is 5.0 VDC.
Output voltage range	From 0.5 to 4.5 VDC @ 5.0 VDC input voltage (2.5 V ± 10mV at 0g)
Operating current consumption	< 400 µA @ 5.0 VDC
Initialization & reset current consumption	Typ. 1400 µA (max. 1500 µA) @ 5.0 VDC during the initialization phase. Initialization phase is less than 35 ms at room temperature
Reset	The sensor is Brown out protected. A reset occurs when the power supply varies by more than +0.46 V with a slope >380V/s or if the power supply drops below 2.2V. The recovery time is typ. 25 ms (max 35 ms)
Impedance of external components	Min. 10 kΩ at Vout (pin 32) and VAGND (pin 38) Max. 50 pF at Vout (pin 32) and Max. 100 µF at VAGND (pin 38)

Physical

Hermetically sealed LCC, 48 pins housing

Weight	Typ. 1.64 grams
Size	Typ. 14.2 x 14.2 x 3.3 mm (0.56 x 0.56 x 0.13 inch) Max. 14.48 x 14.48 x 3.79 mm (0.57 x 0.57 x 0.149 inch)

Temperature sensor:

Output Voltage at 20°C	Typ: 1.632 V
Sensitivity	Typ: -11.77 mV/°C
Long term stability	Max -0.03°C to +0.09°C (1000h @ 150°C)
Accuracy	± 5°C (From -40°C to 125°C)

Block diagram and electrical connections

It is necessary to use decoupling capacitors [C] of 1µF each between VDD and VAGND and between VAGND and VSS, located as close as possible from the accelerometer.

COG or X7R @ 5% capacitor types are recommended. The VAGND track should also be as short as possible

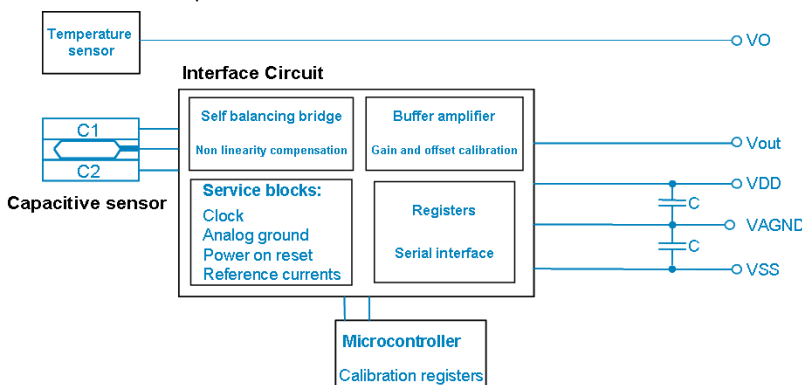

Pin	Description	Remarks
9	VPP (Colibrys internal calibration pin)	Must be connected to VSS
12	SCK (Colibrys internal calibration pin)	Must be connected to VSS
15	SDA (Colibrys internal calibration pin)	Must be connected to VSS
32	Vout	Accelerometer output signal
36	VSS	Ground
38	VAGND	Accelerometer output reference voltage(VDD/2)
40	VDD	Power supply
42	VO	Temperature sensor output

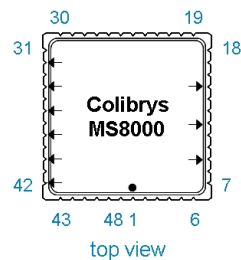

A detailed MS8000 Product Description (30D.MS8X.x.xx.xx) and further Application Notes are available on demand or on our web site.

In order to provide an ideal support to our customers, our

standard MS8000 products are available worldwide through a wide network of distributors and agents or directly at Colibrys. Do not hesitate to access our web site for precise contacts or contact directly Colibrys in Europe or in US for more details.